

DEALER STAMP



HARVEST INSTALLATIONS, UNIT E, NORTH YARD, THE BRENTS, FAVERSHAM, KENT ME13 7DZ

CHC INSTALLATION, COMMISSIONING, OPERATION AND SERVICE MANUAL

CHC INSTALLATION, COMMISSIONING, OPERATION AND SERVICE MANUAL



HARVEST INSTALLATIONS

Constant Humidity Controller™

Installation, Commissioning, Operation and Service Manual

E.C. DECLARATION OF CONFORMITY

In accordance with **EN ISO 17050-1:2004**, We Harvest Installations Ltd of Unit E, North Yard, The Brents, Faversham, Kent. ME13 7DZ in accordance with the following directives:

2004/108/EC The Electromagnetic Compatibility Directive

2006/42/EC The Machinery Directive

hereby declare that

Equipment:- **Constant Humidity Controller**



is in conformity with the applicable requirements of the following documents:-

BSEN ISO12100:2010 Part 1&2 Safety of Machinery Basic concepts general principles for design.

BSEN ISO13857:2008 Safety of Machinery safety distances to prevent danger zones being reached by upper-limbs.

BSEN298:2012 Relating to safety devices on burners ie: programming units, purge fan, flame sensor, overheat sensor and air-flow sensor.

BSEN16129:2013 Relating to pressure regulators for LPG.

We hereby declare that the equipment named above has been designed to comply with the relevant sections of the above referenced specifications and is in accordance with the requirements of the Directive(s)

Signed by: _____ Name: _____ Date: _____

Position: _____ Done at: _____

Document ref. No.ECHI2015.

The technical documentation for the machinery is available from the manufacturers address.

HARVEST INSTALLATIONS LTD
CONSTANT HUMIDITY CONTROLLER
INSTALLATION AND HANDOVER FORM

The Harvest Installations Constant Humidity Controller,

MODEL NO. **SERIAL NO.**

has been installed and commissioned for,

ON: **BY:**

has received proper instruction on the safe operation, setting and controls of this Harvest Installations Constant Humidity Controller.

Signed: _____

Agricultural Harvest Store Installations Ltd. Reg. No. 1439743

Health & Safety at work 1974

Under section 6 of the above act, it is the duty of the manufacturer and suppliers of products for use at work to ensure, so far as is reasonably practicable, that such products are safe and without risk to health when properly used to make available to users of such products adequate information about their safe and proper operation.

Our units should only be used in the manner and purpose for which they were intended, and in accordance with the recommendations detailed in this Manual. Our units have been designed, produced and inspected with safety in mind, but there are certain basic precautions which should be taken by the user and in particular, attention is drawn to the safety precautions in this Manual and in the Operating Instructions on the heater.

It is imperative, therefore that all persons who may make use of our units, have all the information and instruction they require to ensure that they are fully aware of any hazards and that they know both the purpose and the correct manner of use of our units.

Almost all installations of Harvest Constant Humidity Controllers will be defined under the 1997 code of practice as a "Confined Space". Special consideration should be given to highlight the associated risks of working within a confined space. Measures should be taken to limit access into the fan or plant room to authorised personnel only. Correct warning notices should be clearly displayed and if required, access should be locked.

Specific risks are:

- Build up of CO and CO₂ if CHC is used independently of main fan.
- Noise.
- Gas.
- Fire.
- Electric shock.

Use only in well-ventilated area.

Do not use close to combustible materials or gas cylinders.

Not to be used for heating of domestic buildings or as an industrial workplace heater.

Intended use as part of industrial grain drying system only.

In the event of smelling gas, turn off the appliance immediately and shut all gas valves.

Isolate mains electrical supply and gas supply before undertaking service, maintenance or repair work.

Isolate mains electrical supply and gas supply before removing/undertaking work on supply bottles or any part of the gas train.

Inspect flexible gas hose regularly for signs of perishing. Replace with recommended hose only.

For use with vapour take off LPG only. Working pressure 20psi at full flame.

If appliance is used outside the UK ensure all local regulations and requirements are met.

If used in isolation, danger of Carbon Monoxide poisoning.

Fan/Plant room should be locked at all times.

Power supply MUST be connected via a fan run interlock safety circuit. If safety interlock is not available, an air duct pressure cut off switch MUST be used.



Preface

All personnel must have read and understood the Operations Manual before any kind of operation takes place.

All protection guards must be in position before starting.

All Gas and electrical connections must be carried out by experienced installers.

Harvest Installations 2 Year Guarantee

On all burners and electronic components which have become faulty by reason of defective materials or negligent workmanship which covers parts and labour for a period of 2 years, provided they are (in accordance with recognised safety procedures) serviced at least once annually from the date of installation by Harvest Installations approved engineers.

This service is not included in the guarantee and will be charged for at the appropriate rate with the cost of useable parts.

The guarantee is subject to:

1. New equipment only.
2. Use under normal conditions ie protected from direct rain entering fan, burner, electronics.
3. Connections to vapour gas propane supply as per LPG code of practice with correct supply pressure required for the size of units.
4. Electricity supply as per instructions.
5. Installation by our own approved engineers.
6. No exterior physical damage to components ie leads, wires caused by rats, mice etc.
7. No contamination of sensors ie oil, dust, grease, diesel, water.

Exclusions to guarantee:

1. Any damage or malfunction being caused directly or indirectly by the gas or electricity supplies, eg contaminated gas, non-standard electricity supply characteristics etc.
2. Any damage or non-function of the tranquel plug caused as a result of the tranquel plug acting against non-standard electricity supply characteristics.

Introduction

The CHC unit is an electronically controlled vapour offtake propane burner. Its operation is automatic and when correctly sized to the fan, it will control the relative humidity or temperature of the air within the set limit. The CHC when equipped with a temperature sensor can be used for crop heating purposes, again it works automatically to control temperature to a set limit.

The CHC has been designed to run unattended. All CHC units comply with current regulations for unattended propane crop driers.

The CHC unit will give accurate drying providing that it has been correctly matched to the main fan and is installed and used in the manner described in this manual. Providing it is maintained and serviced annually, it will continue to give accurate and reliable performance for many years.

Installation of CHC units

Tanks:

Gas Supply Recommendations

The gas supply must be VAPOUR PROPANE only.

To ensure correct and reliable performance the correct number of cylinders or size of bulk tank must be used. To ensure enough gas vapour is produced to continuously run the CHC under full load conditions with low ambient temperatures ie zero to 10°C.

UNIT	SINGLE ROW	DOUBLE ROW WITH C.O.V.	BULK TANK SUGGESTED SIZE (to be checked with gas supplier)
20S	3	2x2	-
20D	5	2x4	-
30S	4	2x4	-
30D	8	2x8	-
45S	5	2x5	1x1 TONNE
45D	10	2x8	2x1 TONNE
60S	7	2x6	1x2 TONNE
60D	-	-	2x1 TONNE OR 1x2 TONNE
100S	12	2x10	1x2 TONNE OR 2x1 TONNE
100D	-	-	2x2 TONNE
200S	-	-	2x2 TONNE
200D	-	-	4x2 TONNE

If a bulk supply is used it must terminate inside the fan house, at a suitable point, with a ³/₄" male hydraulic nipple and end cap. There must be a pressure of at least 22 p.s.i. available at this point. All special fittings and adaptors to suit older installations are available from Harvest Installations.

When connecting bottles together or the CHC to the supply, always check all fittings using leak detector fluid to check for leaks, and rectify as necessary. This will prevent dangerous and wasteful leaks, and should only be carried out by a competent installer.

Constant Humidity Controller Installation and Commissioning Advice

Health and safety

Not to be used for heating of domestic buildings or as an industrial workplace heater. Intended use as part of industrial grain drying system only.

Competence

CHC units should only be installed and commissioned by authorized Harvest Installations engineers and dealers.

CHC units are portable. Instruction should be given to competent persons to allow safe relocation and connection.

Unpacking

Take care when unwrapping CHC and/or accompanying packages.

Ancillary items are often packed in with the CHC unit. Ensure these are not dropped or damaged during unwrapping.

Handling and moving

Observe HSE guidelines when lifting or moving CHC units.

Transport wheels can be supplied for units that require regular moving.

Parts check

Check all parts are present before commencing work. Contact Harvest Installations immediately if any shortages found.

Electrical supply

The CHC requires only a standard 3-pin socket. No special electrical connections are required. If required, follow all relevant current regulations for installation of weather-proof sockets. All electrical work should be carried out by a qualified electrician.

Gas supply

NEVER alter, or tamper with, the gas supply. ALL work to the gas supply must be carried out by the



contracted suppliers approved engineers. For use with vapour take off LPG only. Working pressure 20psi at full flame.

Fan interlocks

Power supply for the CHC MUST be connected via a fan run interlock safety circuit. If safety interlock is not available, an air duct pressure cut off switch MUST be used.

NEVER OPERATE THE CHC UNIT WITHOUT THE MAIN VENTILATION FANS.

Burner position

Ideally the CHC is positioned at 45° to the main fan at a distance of 0.4m to 0.6m. The CHC should discharge into the fan inlet, although it does not have to discharge centrally into the fan. The CHC may be positioned between 45° and 90° to the fan inlet, although this is not ideal and may result in some reduction in efficiency. Note: The CHC's position in the fan room should

not block or inhibit access to tunnel access or controls.

Access around the CHC is required for servicing. Safe routes should be considered and access between fan and CHC avoided. CHC's may start automatically during normal operation.

Frames

The CHC can be supplied with a variety of support frames. These are specific to each installation. CHC and frame should be assembled together on the floor and then raised into position.

Observe HSE guidelines when assembling and raising CHC frames and units. Burner position is as above regardless of frame design.

Sensor positions

As sensor each installation is different with various fan types, locations and positions, sensor installation can vary widely.

General rules are:

Relative Humidity sensors are fitted inside the main air duct.

Approx' 2m from, and in line with, the main fan outlet.

If larger CHC units are fitted and temperature drying is possible, the relative humidity sensor must be placed outside the main air duct. The sensor should then be placed over a 20mm dia. air hole to allow air from the main air duct to pass over it.

Temperature sensors are fitted on the outside of the tunnel with the sensor passing through a suitable hole.

Both sensors should be placed for ease of access and service.

Care should be taken to avoid locations where sensors are likely to be knocked or kicked.

Both sensors can be placed on connection ducts between fan and main air duct.

Cable routing

All cables within main air ducts should be routed and clipped or tied to avoid sharp bends and edges, or loose sections which may flap and cause fraying or distorted signals.

All cables in the fan room should be routed



and clipped to avoid becoming trip hazards or obstacles. Check for sharp edges or snag points when using building frame or structure. Safely coil and tie excess cable. Ensure sufficient slack can be obtained for service, repair, replacement and connection by looping cables at each end. Secure loops to avoid damage.

Singles, Doubles, Multi's

Irrespective of CHC size, or number of units used, the principle of position is as described above. It is important that each CHC has a power socket individually interlocked to the relevant fan. Multiple CHC units should NEVER be operated from a multi socket extension lead.

Take note of fan run order. The main fan is unlikely to be fitted with a back draft shutter. If in doubt consult the electrical engineer responsible for the installation.

The master CHC unit is fitted with the main control panel and will have a slave lead socket. This unit MUST be located in front of the main fan. A CHC slave unit will have a 5-pin slave lead fitted to the control box.

On double units, route slave lead as per other cabling, to avoid trip hazards and snags.

When assembling double units on a common stand, assemble the stand and top CHC at floor level. Raise the stand and position in front of the fans. Install the bottom CHC unit and make cable connections. Observe HSE guidelines when assembling and raising CHC frames and units.

Multiple CHC units will be fitted with a signal booster box. This box is used to distribute the master CHC's control signal to all slave units. Position and fix to allow all cables to be correctly routed.



Gas connections

The standard connection on all new CHC units is a 3/4", high flow POL fitting. This connects to a gas main fitted with a matching 3/4" hydraulic nipple. An old style 7mm POL adaptor can be supplied if required. There should be a gas shut off valve within reach of the CHC. Gas pipes should be clearly labelled and MUST not be altered or modified unless by a qualified gas engineer.

Purging and leak testing should have been done before connection of the CHC unit.

Each CHC installation is fitted with a high capacity regulator and gauge. Factory set for operating pressure of 20psi at full flame. Care should be taken when handling and installing as gauges are easily knocked and damaged.

Gas hose routing and fixing

Lay out the supplied gas hose between CHC and supply before making connections. Hoses become easily twisted during fixing. As far as possible, try to reduce trip hazards, or causing obstructions whilst routing the hose. When fixing hoses be careful not to crimp or distort the hose. Avoid tight bends and look for any sharp edges that may degrade the hose.

Double and multiple CHC installations require connection of the hose to the unit on site. Hoses can be cut to length on site, excess may cause a hazard. Use only supplied clips for connection of hose to CHC. Ensure hose fits fully over its nozzle and clips are fully crimped. Hose can be fixed to support frames to help keep lines tidy.

Leak testing

Only use proprietary leak test spray. These sprays are designed to highlight LPG and give guaranteed results compared to home-made options.

Inspect the complete gas train and ensure all connections are tight. Check that the gas is turned on at the tanks and follow the gas line to the CHC checking all valves are open. Turn on the last valve next to the CHC and look for correct pressure on the regulator gauge (21-22psi static pressure). Have a cloth handy and spray each joint and connection, from the gas tap onwards. If leaks are found in the mains line, turn off ALL gas taps and report it. Mains gas work can only be carried out by the suppliers own engineers. Check the connection between the main and regulator carefully, cleaning excess spray as you go. Check all joints and connections.

Start up

WEAR APPROPRIATE EAR PROTECTION. Start main fan. Look to see that CHC socket becomes live only as fan reaches full speed. Plug in click box, turn box from min' to max' and watch that display reacts correctly. Ensure selector switch is on RH. Set point is 0.5 – 1.0 above click box min' reading. Turn CHC on. Look for correct fan operation and ignition. Once ignited starts run checks.

Stage checks

Using the click box, cycle the CHC through all 7 stages, both up and down its range. If possible, view flame shape during checks. Ensure low flame setting engages with flame probe and high flame is contained within the CHC case. Operating pressure, 20psi.

Run down

Once all stages checked and CHC operation is ok, turn click box to min' to initiate run down. Time the run down. It should be approx' 2 minutes. Once run down is complete, turn click box back up to restart CHC. Repeat run down and turn off CHC. Before turning fan off, disconnect click box and reconnect sensors. Check readings are acceptable against ambient conditions and shut



down main fan. For double and multiple units, repeat process for each CHC in turn. Finally, operate all units together.

Signs

Fix Harvest Installations fan / plant room safety sign to outside of all access doors. Fix Carbon Monoxide warning notice to main control panel.

Tidy up

Make a final inspection of the complete installation. Check all cable and hose routes are tidy and as far as possible do not form a trip hazard or obstacle to normal operation. Collect all packaging and place tidily for client disposal.

Setting the CHC instructions

1. Switch electricity supply unit on, on systems where an interlock is fitted it may be necessary to run main fan. Check the R.H. sensor is plugged in. Leave the heat switch in the OFF position.

2. Check that T/RH switch is in the RH position.

For RH control or T position for temperature control with the appropriate sensor connected.

3. Having established the highest moisture content of the crop, not the average, reduce this figure up to 2% in grain depths over 3.0m (10') or by up to 3% for on floor stores where grain depth does not exceed 3.0m (10'). Establish the required R.H.% to give the desired moisture content after reductions as above.

EXAMPLE:- Highest moisture content = 18%
Desired final moisture content = 14%
Assume gain depth over 3m (10')
18% - 2% = 16%
For barley 75% R.H. will give 16% m.c.

Moisture content - relative humidity %equilibrium for various seeds, at 15°

Drying% RH of Air	55	60	65	70	75	80	85	90
Wheat %m.c.	13	13.5	14.5	15.5	16.5	17.5	19.2	20
Barley %m.c.	12	13	14	15	16	17.8	19	19.5
Oats %m.c.	11.5	12.5	13	14	15	17	19	20
Rape %m.c.	7	7.5	8	9	10	12	14	16
Peas %m.c.	12	13	14	16	18	21	24	27
Ryegrass %m.c.	11	12	13	14	15	16.5	20	24
Beans %m.c.	12	13	14	16	18	20.5	23	26

NOTE: For winter time drying (average 5°C) set RH approx. 10% lower to obtain same moisture content as at 15°C. ie for wheat 60% RH= 15.5 moisture content.

4. Now set CHC to the required relative humidity. For above 75% RH Press and hold the square SET button, turn adjusting knob until 75.0 is displayed on the LCD panel. Release the SET button, the target relative humidity is now set and the LCD panel will show the actual relative humidity as measured by the sensor.

5a. With the main fan running turn on gas and move heat switch(es) to ON position. The CHC will now operate as demand dictates.

b. Close the hinged cover of the CHC.

6. Assuming demand ie. actual RH is higher than set RH the CHC start and run sequence is as follows.

a. Burner fan starts and runs, nothing else happens for approximately 30 seconds.

b. Gas and ignition commence, flame established.

c. Unit modulates to match requirements.

d. When actual RH is equal to or less than target RH the CHC will be on flame stage one. Then after two minutes, providing actual RH is below set RH the CHC will switch off, until such times as the actual RH% rises above the set point. It will then automatically restart and run again as necessary.

Adjustment of gas pressure to match fans

All CHC units are fitted with an adjustable gas pressure regulator. This allows the output of the unit to be adjusted to give a range of outputs up to the maximum rated output. This feature allows the use of the CHC on fans of various outputs whilst maintaining accuracy.

The specified gas pressures on all units are to be set with the CHC on maximum flame. To set gas pressure, dial in a low set point ie 20% RH with sensor plugged in, run CHC. It will now be on full flame, adjust pressure to desired level. Reset humidity to correct required set point.

Remember on multiple units all modules must be running to adjust pressure correctly.

Pressure Output Chart

Remember to set pressure with unit(s) on full flame.

With double units keeping the same pressure will double the output.

With triple units, keeping the same pressure will triple the output.

MODEL	PRESSURE P.S.I	NOMINAL OUTPUT BTU/HR
CHC 20S	7	125,000
	12	160,000
	20	200,000
CHC 30S	7	190,000
	12	240,000
	20	300,000
CHC 45S	7	280,000
	12	360,000
	20	450,000
CHC 60S	7	375,000
	12	480,000
	20	600,000
CHC 75S	7	470,000
	12	600,000
	20	750,000
CHC 100S	7	630,000
	12	800,000
	20	1,000,000
CHC 150S	7	945,000
	12	1,200,000
	20	1,500,000
CHC 200S	7	1,250,000
	12	1,600,000
	20	2,000,000
CHC 225S	7	1,406,000
	12	1,800,000
	20	2,250,000
CHC 250S	7	1,563,000
	12	2,000,000
	20	2,500,000
CHC 300S	7	1,875,000
	12	2,400,000
	20	3,000,000
CHC 350S	7	2,188,000
	12	2,800,000
	20	3,500,000
CHC 400S	7	2,500,000
	12	3,200,000
	20	4,000,000

Humidity Drying

Preparation:

Keep accurate data of incoming grain, recording moisture contents in the store and locations of any over wet areas. Set your CHC to the HIGHEST moisture content, not the average.

Level the top of the crop. This prevents air short cutting through low spots and hollows, leaving wet spots in the crop.

With grain over 18% moisture content, set the CHC to 80% and ventilate continuously until the crop has reduced to 18% moisture.

Airflow:

Calculated at 100cf/m per tonne of crop, it is important to keep good airflow through the stack at all times. This allows the air to collect its maximum capacity of moisture from around the crop whilst maintaining continuous ventilation and preventing stale areas of air developing. Typical air speeds measured at the top of the stack are 15 to 20 f/m.

Duct pressures are a good way to gauge fan performance and readings on a water pressure gauge (Manometer) should typically be between 3.5 and 4 inches.

Opening, to reduce tunnel pressure, or closing, to increase tunnel pressure, is an ideal way to alter pressure readings and ensures maximum tonnage dried for any given fan performance.

Humidity Settings:

Crop moisture content and air Relative Humidity values are directly related. A relative humidity value of 65% equates to a grain moisture content of 14.5%. It is virtually impossible to overdry grain crop using the correct settings and an accurate humidity controller.

A full table of values is shown in the manual and on each CHC machine.

In order to dry efficiently, it is important not to try and dry down to final target values too quickly. A programme of staged removal of 2% moisture should be used. ie. 19% to 17% to 15% to finished dry stored crop. Regular readings should be made to ensure even drying and so changes to settings can be made at the optimum time to save on fan run time and gas usage.

Dry Early:

Generally speaking, post harvest weather lends itself to making the best use of free drying and low gas bills when extra heat is required to maintain incoming Relative Humidity values. If the drying is left until later into the autumn when ambient temperatures are generally lower and Humidity higher, changes are required to CHC settings to maintain correct airflow into the store. This results in higher gas usage and longer drying times.

Air Extraction and Condensation:

It is vital during drying to maintain the correct airflows over the top of the crop and exhaust to the outside. If the drying season is being extended into the latter part of the year when cold nights are a possibility, the store should be closely monitored to prevent condensation delaying the drying process.

Forced air extraction is now the norm for new grain stores and for most conversions.

This is a vital part of the efficient working of the system. As such it should never be overlooked during normal running of the store.

place when not in use. This protects it from damp and possible expensive rodent damage.

Final Drying:

Removing the last 0.5% of moisture from the crop takes the longest time. Be patient. It may help to set incoming air 1 or 2% below the values shown on the equilibrium chart.

This will help with final finishing of the drying. As always, maintain a good system of sampling and testing to ensure final product quality.

Time Scale:

Once the store is loaded enough to allow running of the fans, get things started. Set the CHC for the highest moisture content and turn on the fans. Ventilate 24 hours a day! It is a false economy to turn fans and burners off overnight to save power and gas. Up to 4 or 5 hours of drying can be required to get the stack back to where it was before making any new progress drying.

Keep it turned on.

Drying performance varies depending on ambient conditions, store design, store age and condition, and of course crop condition. However as a general rule, it is expected that between 0.3 and 0.5% moisture extraction should be possible from the stack in a 24Hr period.

The quick check list for your CHC drying

1. Level crop.
2. Correct ducts/laterals/bins open.
3. Not more than 2% m.c. reduction from wettest part of crop to be dried when grain depth exceeds 3.0m (10'). A 3% m.c. reduction can be applied where grain depth is less than 3.0m (10').
4. Main fan back pressure not exceeding 4" w.g.
5. Air flow measured on top of the crop in the range 15 to 25 c.f.m.
6. Run plant 24 hours a day.
7. Adequate gas supply available to CHC.

Care and Maintenance of your CHC

1. Ensure unit is kept in a dry area when not in use and protect from elements when in use.
2. Regularly clean dust and debris from unit.
3. Always be mindful of the damage rodents can cause to the unit and sensor and take steps to avoid this.
4. When moving unit take care not to damage or drop the unit, and always ensure that the sensor lead is disconnected before attempting to move the unit.
5. Always operate unit in accordance with manufacturers instructions.
6. Always remove sensor from its working position on completion of drying. Keep it in a dry place when not in use. This protects it from damp and possible expensive rodent damage.
7. Regularly check sensor foam cover. Keep it clean and replace if necessary. The securing clip is reusable.
8. Have your burners serviced annually by a Harvest Installations approved engineer to maintain safe, accurate and economic performance.
9. At the end of the drying season it is good practice to shut off and drain the main gas supply. Turn off supply at nearest stop valve to gas tanks. Start the CHC and run until the flame goes out and the pressure at the regulator shows zero. Turn off the burner and shut down the remainder of the gas stops in the supply back to the tank.

Lockouts

If the red button is illuminated and the machine has stopped it can be reset by pressing the red button when it should restart, if lockout re-occurs follow procedure below:

Lockout can be caused by a wide range of faults. Lockouts can occur under three general conditions. They are:

1. On start up.
2. Shortly after start up.
3. At some point whilst running.

Having established when the lockout happens, the next step is to clarify what is or isn't happening. Read all of this information before starting checks. Observe normal safety precautions e.g. unplug unit when checking it through.

Condition 1: Locking out on start up

- A. Is the gas turned on and does the regulator gauge show pressure?
- B. Can a spark be seen between the ignition probe and burner head?
- C. Can gas be heard or smelt during what should be the start up period?

Action assuming a "no" to A, B or C

- A. Turn gas on, adjust pressure to recommended figure. This will need to be checked once unit is running normally.
- B. Check gap between burner head and ignition probe should be 2-3mm. Ensure ignition probe is clean and dry. Ensure ignition lead is going to ignition probe is clean, dry and not shorting out.
- C. Assuming gas supply is correct and ignition spark is clearly visible, and set at correct gap, and no gas can be heard or smelt entering combustion chamber. Check for magnetic pull on the tops of the inlet valve using a small screwdriver or hacksaw blade when unit is trying to start. These are two valves, in series, the first valves as the gas reaches the unit. If magnetic pull is felt on both call Harvest Installations.
 - i. The 3.15 amp fuse, if fitted, is OK.
 - ii. The overheat stat fitted in the combustion chamber, bypass this by joining the two wires together.
 - iii. The air switch, bypass this by joining the two wires together

After first (ii) then (iii) try to run unit. If unit starts and runs OK after (ii) or (iii) the fault is located, if unsuccessful contact Harvest Installations.

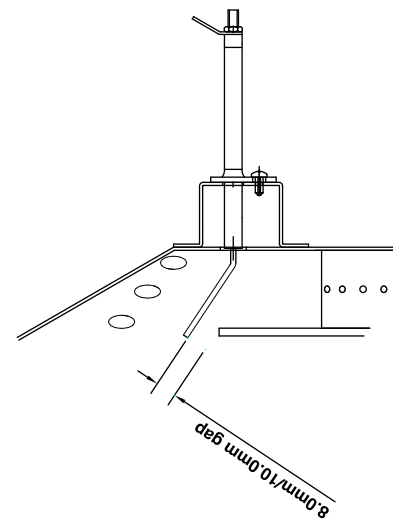

Flame Probe Fitting CHC 100, 125, 200, 225

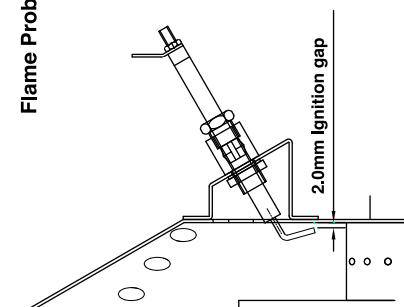

Ignition Probe Fitting All CHC Models

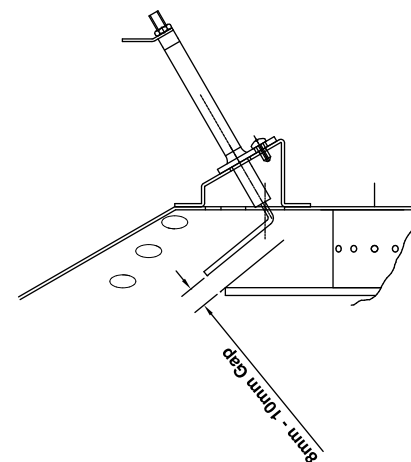

Flame Probe Fitting CHC 20, 30, 45, 60, 75.

Condition 2: Locking out shortly after start up having lit first

The unit starts and ignites correctly but then locks out after 10 seconds approximately. This is caused by a flame sensing fault. Check that:

Remove burner head and check:

- A.** The flame probe is clean and dry and not touching the burner head. Clean and adjust if necessary.
- B.** The wire to flame probe is clean, dry, making good connection and not shorting out.
- C.** The pins of the 3 pin plug are clean, and that the wires are all making good contact.
- D.** The most common cause of this lockout condition is when the unit is being used on an extension lead. The extension lead having a poor earth, or most commonly on home made extension leads the live and neutral wires being reversed. Power tools etc. will not detect this but flame sensing system on the CHC unit will!
- E.** Occasionally the power supply in the building has a poor earth, or the socket in use has been wired with live, neutral reversed. This needs to be checked by a competent electrician.

Condition 3: Locking out at some point whilst running

This condition is the most difficult to detect. Some possible causes are as follows:

- 1.** Insufficient volume of gas available e.g. not enough bottles, or bottles or bulk tank very low on contents.
- 2.** The unit has got one of its stages missing, check fuses fitted in control box.
- 3.** The unit is being affected by the main fan causing the burner fan to rotate in reverse when not running. Reposition burner according to instruction book.

IF ANY OF THE ABOVE 3 AREAS PROVE NOT TO BE AT FAULT THEN A SERVICE CALL WILL BE NECESSARY.

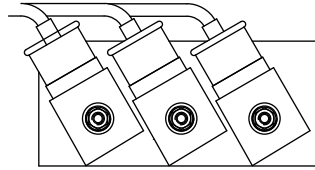

MODULATING VALVES MACLAREN
MA732-009P32/10 SAW 230/50
USED ON ALL MODELS

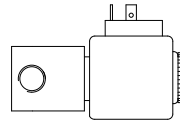

MAIN VALVE MACLAREN
MA233-009P SAW 240/50
USED ON CHC 20/30/35/45 MODELS

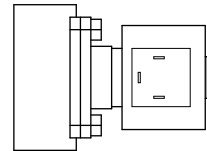

MAIN VALVE ASCO
SCE 2110 C94 1/2" 400 425 117 230/50
USED ON CHC 60/75/100/200 MODELS

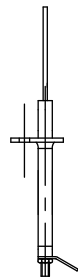

FLAME PROBE 100/200 MODELS CHC 250

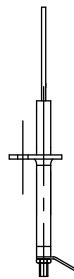

FLAME PROBE 20/30/35/45/60/75 MODELS CHC 100

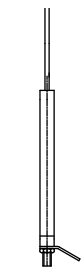

IGNITION PROBE ALL MODELS CHC 200.047

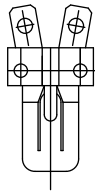

LIMIT THERMOSTAT - V10/20
USED ON ALL MODELS

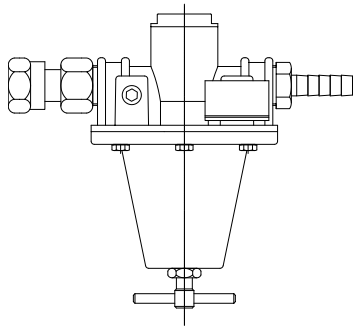

REGULATOR
AP2000
USED ON ALL CHC
20, 30 & 35 MODELS
ALSO USED ON CHC455
REGULATOR
AP2000
USED ON CHC45D
AND ALL LARGER MODELS
MAXIMUM RATED CAPACITY 6,000,000 BTU/
HR

Operating instructions for drying in square silo plants

1. Open the air doors into the silos that require drying.
2. Start up the main fan unit.
3. Very important. Check the back pressure on the dial manometer. Make sure the water gauge is no higher than 5". (It will work better at 4" WG or less). The back pressure can be lowered by opening more silos, or by partially blanking off the fan inlet.
4. Level out the crop in the silo. Use an air flow meter to ensure there is even air flow over the area. Try to ensure the air flow is 15-25ft per minute, with a minimum of 12ft/minute.
5. Set the RH setting on the Harvest CHC unit as per instruction book, or under the lid. As this is a silo plant it is advisable to operate the unit at 2% MC drops, with wet material start with the RH setting at around 80% RH.
6. Having set the store, run the fan 24 hours a day with the CHC unit switched on and operating continuously. This will ensure quick and even drying to the required moisture content.

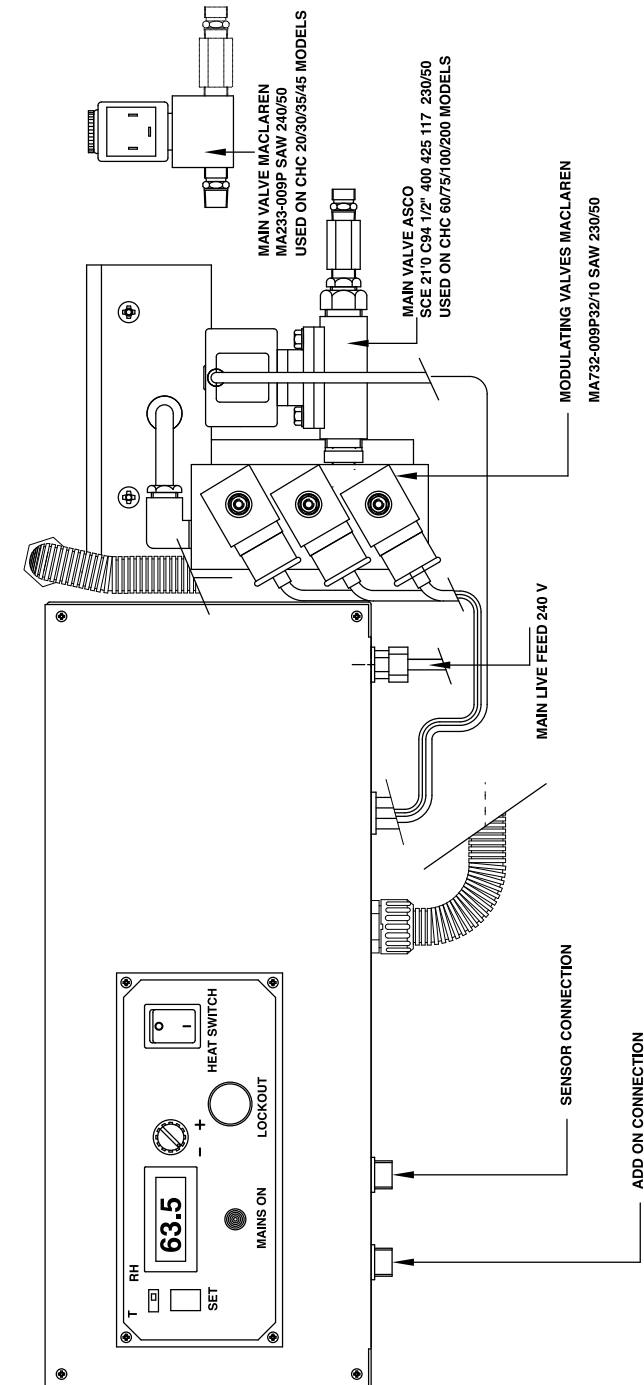

Constant Humidity Controller Service Manual

Health and safety

Only operate CHC in well-ventilated area with main fans running.

Use ear defenders whilst running main fans.

Disconnect CHC from main electricity supply before undertaking any service work.

Isolate main gas supply before undertaking any service work.

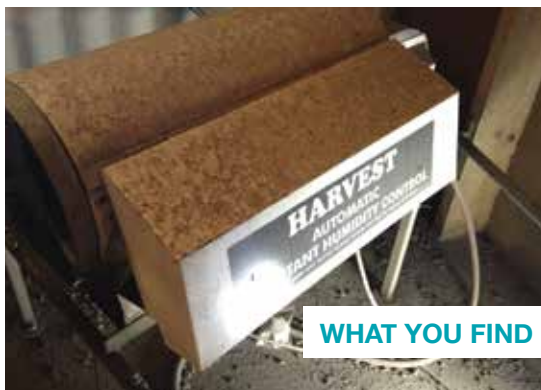

Initial inspection

Make a full visual inspection of the CHC installation before running up. Check for any obvious damage to gas hose or mains lead. Inspect CHC for signs of damage or misuse. Check area is safe before running up, (ie, no stored flammable items, or obstructions to proper operation).

Running up

Start main fan and look for correct operation of safety interlock to CHC power supply.

Sensor accuracy

Before starting CHC, check operation and accuracy of sensor(s). Make any adjustments to relative humidity sensors before starting main service work to allow the sensor to settle before rechecking. If access to main air duct is required, ensure fan interlock is operated to prevent main fans starting. If no interlock is fitted, isolate the main fans.

Start CHC

Check for smooth running of fan and clean ignition. Visually check flame shape for full, even burn. Adjust set point to achieve low flame burn, and full flame burn. Check display remains stable after changes to set point.

Whilst on full flame, check all stage coils for correct operation. Blank off part of main air inlet to fan to check operation of air switch.

Check operating gas pressure on full flame.

Turn off CHC. Turn off main fan.

Disconnect CHC from mains supply.



Isolate gas supply.

Whilst CHC cools, brush clean the outside case, fan and the fan guards.

Control box(es)

Check all connections on Main PCB. Tighten top terminal connections if required.

Visually inspect for any signs of damage.

Remove satronic box and visually check condition. Check connections on base plate are tight. Refit box.

Remove the protective cover on the air switch and check terminals. Remove air supply tube and blow down it to ensure it is clear.

Inspect main terminal board condition and check all connections. Ensure mains lead connections are tight. Check 100mA fuse covers are in place and spare fuses are in place. Check earth connection.

Check slave and sensor sockets are secure,



and wires are not twisted. Check feel of sensor plug into socket is not loose as this may cause intermittent or faulty readings.

Make sure all connections onto fan contactor are in place and in good order.

Inspect back of panel lid for on/off switch and display connections. Ensure earth connection is secure.

Brush clean inside the control box(es).

Clean boxes outside.

Valve block

Visual check of all coils and leads. Ensure all leads are correctly marked and remove coils from valves. Clean leads plugs and coils. Check that all plugs have fixing screw in place. Check for any shape distortion on coils, or any signs of overheating. This can be a warning of future failure. Take extra care when removing and cleaning old type "ladder" coils.

Retaining nuts can seized and cause damage to the valves if forced. Clean and visually inspect main inlet valve.

Inspect main valve block for signs of damage, cracking or overheating.

Clean. Check bundy tube fitting, and pipe on valve block.

One at a time, remove stage valves. Take care not to lose O-ring, plunger or spring. Check each valve for smooth operation. Pay close attention to top plunger clearance in valve. Clean and reassemble. Fit coils to all valves and tidy cables.





Gas Filter

If possible, remove, inspect and clean in line filter in gas line. Note that older filters are fitted to the CHC, whilst new models have the filter before for regulator.

Inspect all gas hoses. Particular attention should be given to any hose which is routed outside the fan room. If in any doubt, replace it. Check the hose is not trapped or crimped at any point and that it has no sharp twists or bends. Clean and inspect the regulator and all connections. Ensure correct operation of pressure gauge.

Use a proprietary gas leak spray to test each gas joint, from mains connection through to hose connection on CHC.



Sensor and Cable

If required, enter main air duct to inspect and clean sensor. Ensure fan interlock is operated to stop main fan starting. If no interlock is fitted isolate the fans.

Locate the sensor and remove the foam dust cover. Replace with a new item.

Wipe clean the sensor and cable, checking the sensor lead along its full length.

Look for snags or pinch points that may damage the cable. Ensure cable is clipped at regular intervals as slack cable can move about the air of the tunnel and disrupt the signal. Follow remainder of sensor lead outside the duct back to the CHC.

Thoroughly clean CHC case and lid. Dust down support frames. Inspect all base or support frames and fixings. Ensure frames are secure and stable. Check fixings between CHC and frame are secure.

Restarting and Checking.

Make sure main air duct doors are closed and interlocks turned off. Start main fans to check reading on sensor. Plug in click box and set to 0.5 - 1.0 above minimum setting. Now take the CHC up through all 7 stages in turn. Check operation of all coils with a magnetic tester. Cycle the CHC through its stages several times to ensure correct operation. Turn click box down to minimum and time the CHC rundown. After 2 minutes the CHC should turn off. Turn up the click box to restart the CHC and repeat rundown.

Inside Jobs

From inside flame tube, ping, flame probe. It should be 5mm from the burner plate and secure. From top of CHC, check flame probe is clean and secure.

Ensure good clearance around probe where it passes through burner dish.

Visually inspect for damage of insulating ceramic sleeve. Check terminal connection.

From inside flame tube, check ignition probe is clean and 2-3mm from burner dish. Clean with a small brush. From top of CHC check ignition probe is clean and secure. Ensure good clearance around probe where it passes through burner dish. Visually inspect for damage of insulating ceramic sleeve. Check terminal connection.

Thoroughly inspect burner tube, dish and plate for excessive wear or damage.

Burner plates can become distorted and cause short to flame probe. Ensure fixings are tight.

Inspect ignition pack for any sign of damage and ensure secure. Inspect HT lead, connections each end and that the lead cannot short out on CHC case during normal operation.

Fit new overheat stat'. Inspect wiring for damage and check connections.

Inspect all internal gas pipes and joints. Great care needs to be taken on older machines where it is easy to damage the fine gas tubes.

Check for smooth fan rotation and clean the fan blades to remove dust and dirt build-up.

Clean inside the CHC case. Future service or breakdown repairs become much easier if the machine is kept clean.

Once dirt and dust is removed, coat all fixings with a light coat of WD40 or similar protecting oil.

OLD TYPE CHC. Air switch and fan contactor are mounted in the rear of the unit.

Inspect, clean and protect as above.

Thoroughly inspect all wiring, connections and routing. Clean and remake routing if required. Check for rodent damage and repair/replace as appropriate. Check earth connections are tight and a good contact with the main case in maintained.

Check routing of flame probe cable in particular and ensure it is secure. Check all grommets and/or glands are in place and secure.

Flame Tube.

Remove flame tube guard or star baffle if fitted. With a stiff brush, clean the flame tube inside, and out. Inspect for any signs of wear or severe corrosion, on older machines.

Mains lead. Inspect and clean lead and plug. Check for any damage or pinching.

Remove cover of tranquil plug, if fitted. Clean inside the plug and check terminal connections. Refit cover.

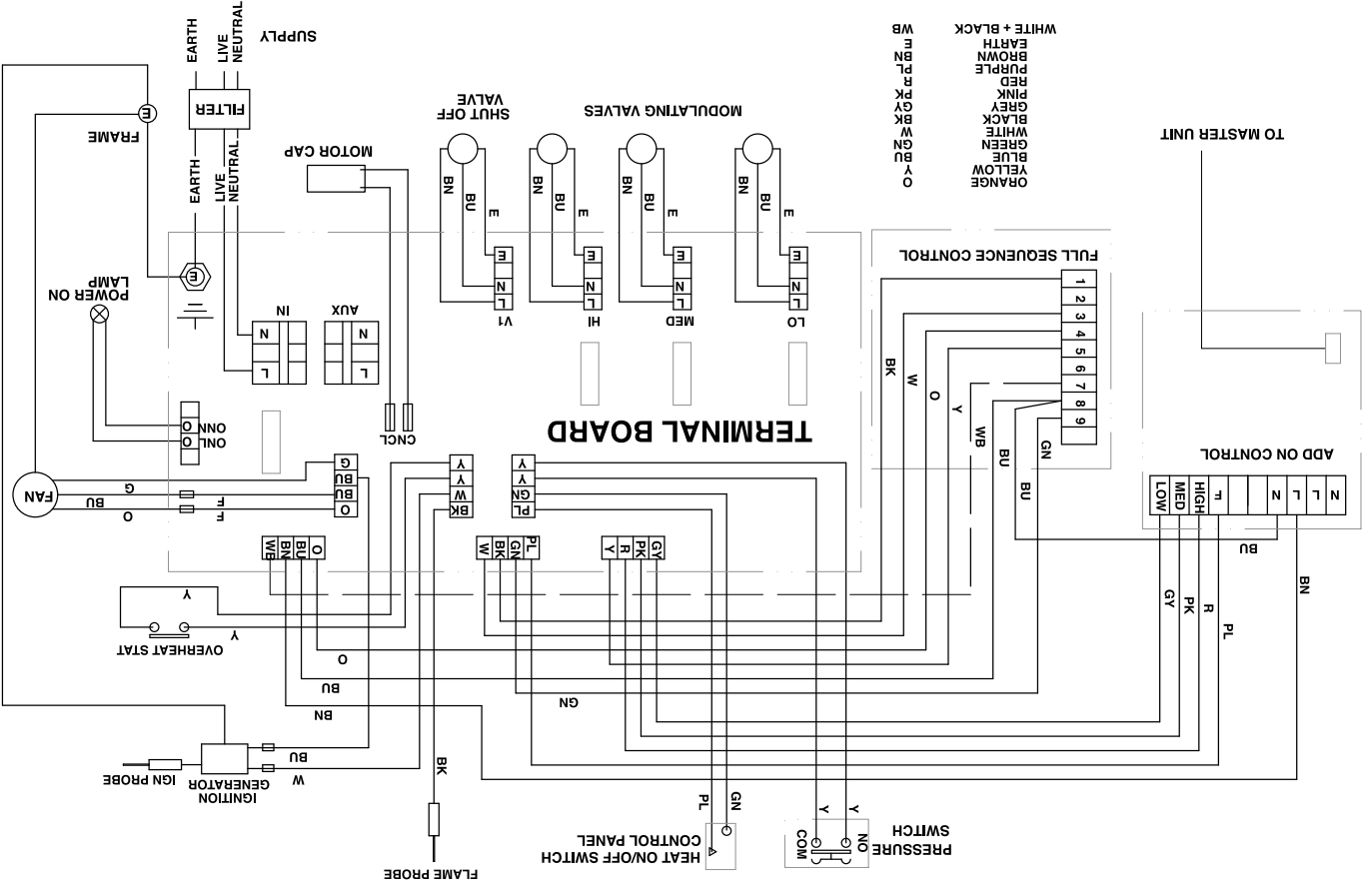

Add on wiring diagram CHC 20, 30, 35, 45

- ORANGE
- YELLOW
- BLUE
- GREEN
- WHITE
- BLACK
- PINK
- RED
- PURPLE
- BROWN
- EARTH
- WHITE + BLACK
- WB
- Y
- BN
- GN
- W
- BK
- GY
- PK
- R
- PL
- E

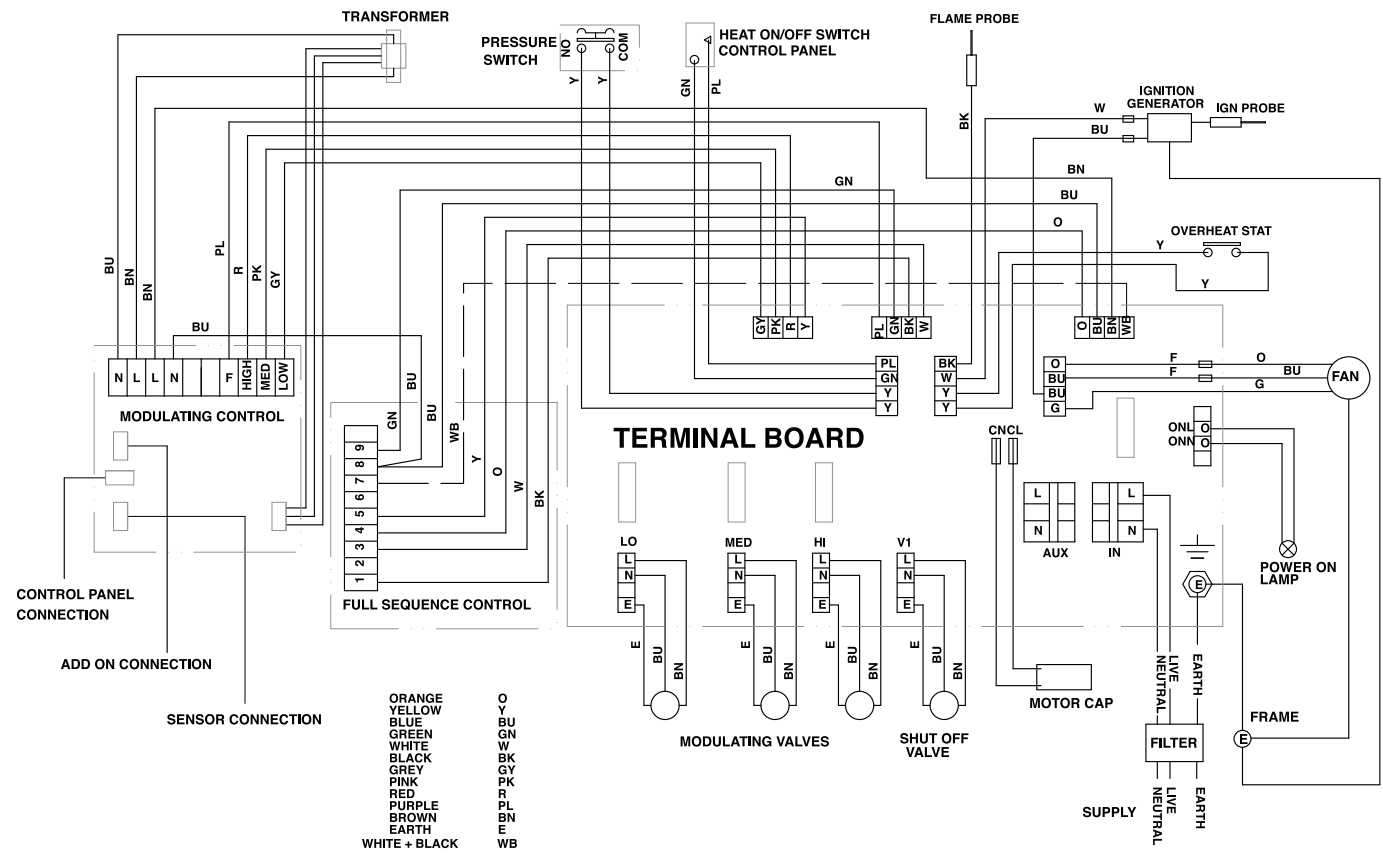

- ORANGE
- YELLOW
- BLUE
- GREEN
- WHITE
- BLACK
- GREY
- PINK
- RED
- PURPLE
- BROWN
- EARTH
- WHITE + BLACK
- WB
- Y
- BN
- GN
- W
- BK
- GY
- PK
- R
- PL
- E

Wiring diagram CHC 20, 30, 35, 45

Notes:

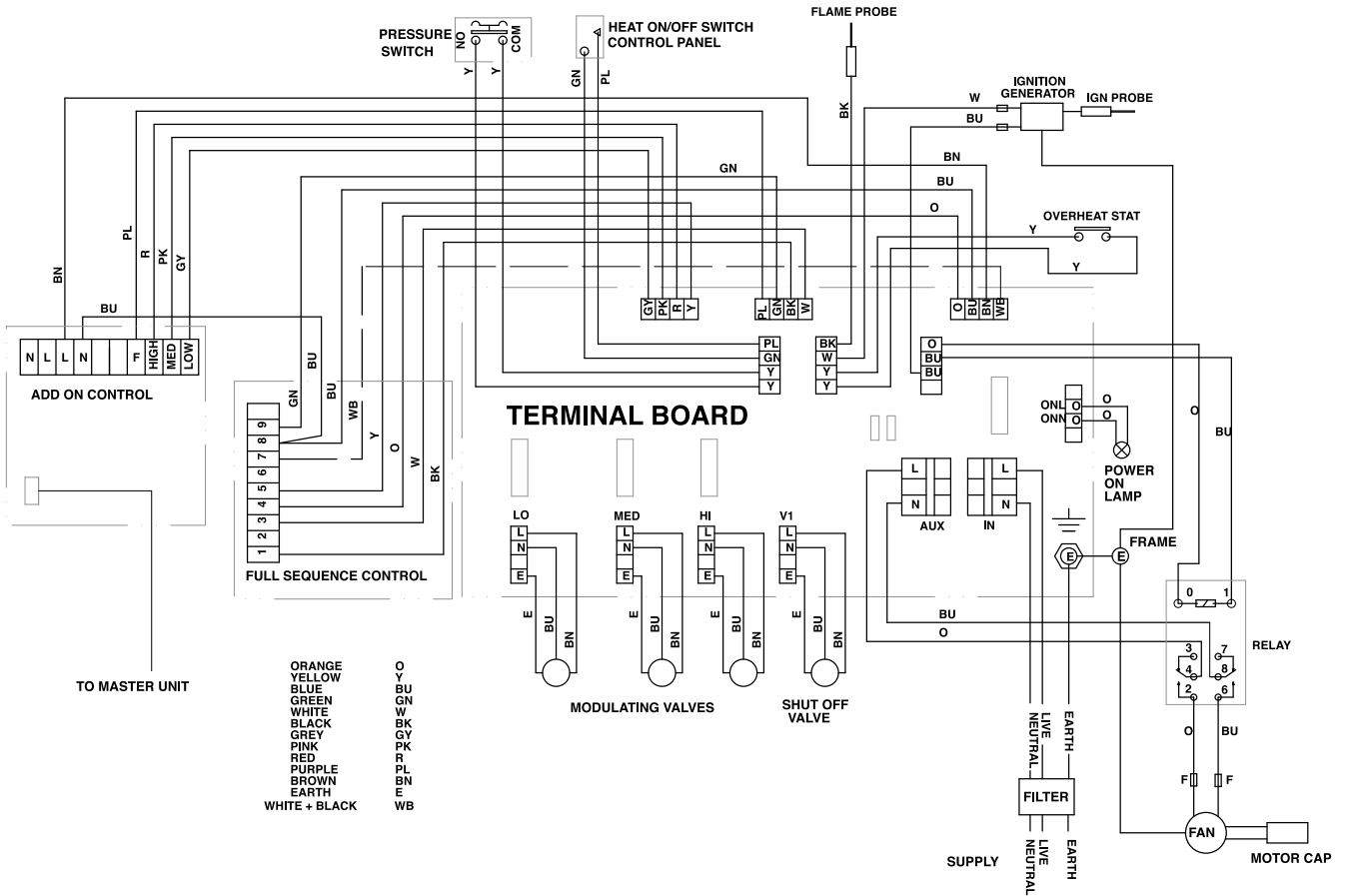

Add on wiring diagram CHC 60, 75, 100, 200